

Released 2012
Achievement Test

Science

GRADE

9

Alberta  Government

This document contains a full release of test items from the 2012 Grade 9 Science Achievement Test.

A test blueprint and an answer key that includes the difficulty, reporting category, unit, and item description for each test item are also included. These materials, along with the [Program of Studies](#) and [subject bulletin](#), provide information that can be used to inform instructional practice.

[Assessment highlights](#) provide information about the overall test, the test blueprints, and student performance on the Grade 9 Science Achievement Test. Also provided is commentary on student performance at the acceptable standard and the standard of excellence on the Achievement test. This information is intended for teachers and is best used in conjunction with the multi-year and detailed school reports that are available to schools via the extranet. **Assessment highlights reports** for all achievement test subjects and grades will be **posted on the Alberta Education website every year** in the fall.

For further information, contact

Matt Dodd, Grades 6 and 9 Science Team Leader (Acting), at Matt.Dodd@gov.ab.ca or

Robyn Pederson (Acting), Director of Provincial Achievement Testing, Robyn.Pederson@gov.ab.ca, at the Provincial Assessment Sector, or call (780) 427-0010.

To call toll-free from within Alberta, dial 310-0000.

[Alberta Education](http://education.alberta.ca) website: education.alberta.ca

Copyright 2015, the Crown in Right of Alberta, as represented by the Minister of Education, Alberta Education, Provincial Assessment Sector, 44 Capital Boulevard, 10044 108 Street NW, Edmonton, Alberta T5J 5E6, and its licensors. All rights reserved.

Special permission is granted to **Alberta educators only** to reproduce, for educational purposes and on a non-profit basis, parts of this document that do **not** contain excerpted material.

Excerpted material in this document **shall not** be reproduced without the written permission of the original publisher (see credits, where applicable).

2012 Test Blueprint and Item Descriptions

The following blueprint shows the reporting categories and topics by which questions were classified on the 2012 Grade 9 Science Achievement Test.

Topic	Question Distribution by Reporting Category		Number of Questions (Percentage of Total Test)
	Knowledge	Skills	
Biological Diversity	4 (1, 2, 4, 9)	7 (3, 5, 6, 7, 8, 10, NR1)	11 Questions (20%)
Matter and Chemical Change	6 (11, 12, 16, 18, 19, 20)	5 (13, 14, 15, 17, NR2)	11 Questions (20%)
Environmental Chemistry	3 (24, 26, 30)	8 (21, 22, 23, 25, 27, 28, 29, NR3)	11 Questions (20%)
Electrical Principles and Technologies	4 (31, 33, 35, 40)	7 (32, 34, 36, 37, 38, 39, NR4)	11 Questions (20%)
Space Exploration	5 (41, 43, 48, 49, 50)	6 (42, 44, 45, 46, 47, NR5)	11 Questions (20%)
Number of Questions (Percentage of Total Test)	22 Questions (40%)	33 Questions (60%)	Total Test 55 Questions (100%)

The table below provides information about each question: the keyed response, the difficulty of the item (the percentage of students who answered the question correctly on the English form of the test), the reporting category, the topic, and the item description.

Question	Key	Correct Response	Reporting Category	Unit	Item Description
1	D	64.7%	Knowledge	Biological Diversity	State which type of species would likely become extirpated if there was an environmental change
2	C	76.2%	Knowledge	Biological Diversity	Identify the type of reproductive process described in a source
3	C	63.8%	Skills	Biological Diversity	Analyze the transmission of characteristics from parents to offspring and predict the colour of the offspring
4	B	48.2%	Knowledge	Biological Diversity	Identify which sexual reproduction stage will have half the number of chromosomes
NR1	312	57.7%	Skills	Biological Diversity	Identify characteristics of DNA, genes and chromosomes
5	D	77.3%	Skills	Biological Diversity	Analyze a graph and determine a predator/prey relationship
6	C	69.7%	Skills	Biological Diversity	Determine an advantage of asexual reproduction based on a source
7	D	43.3%	Skills	Biological Diversity	Describe the relative number and types of species in ecosystems in relation to the equator
8	D	66.5%	Knowledge	Biological Diversity	Identify the responding variable in a population study
9	A	82.5%	Skills	Biological Diversity	Identify the biotechnology responsible for a described procedure
10	B	60.0%	Knowledge	Biological Diversity	Identify an example of discrete and continuous variation based on an evaluation of human characteristics
11	D	77.2%	Knowledge	Matter and Chemical Change	Recognize that the melting of ice is an example of a physical change
12	D	66.2%	Skills	Matter and Chemical Change	Identify an appropriate title for a diagram of molecules
13	C	42.6%	Skills	Matter and Chemical Change	Identify a correctly named chemical formula
14	D	41.9%	Skills	Matter and Chemical Change	Associate a chemical equation with its appropriate word equation

Question	Key	Correct Response	Reporting Category	Unit	Item Description
15	B	62.3%	Knowledge	Matter and Chemical Change	Identify the structure of the periodic table
16	A	61.3%	Skills	Matter and Chemical Change	Determine the classification of chemicals
17	A	62.6%	Knowledge	Matter and Chemical Change	Determine the number of electrons and neutrons in an atom based on information from the periodic table
18	C	69.5%	Knowledge	Matter and Chemical Change	Identify characteristics of corrosion and combustion reactions
19	D	82.1%	Knowledge	Matter and Chemical Change	Identify factors that increase the rate of a reaction
20	C	74.3%	Skills	Matter and Chemical Change	Evaluate information to determine the type of reaction that is described
NR2	212	68.4%	Skills	Matter and Chemical Change	Classify substances as ionic or molecular based on information in a source
21	B	81.7%	Skills	Environmental Chemistry	Analyze two sources of information to answer a question about green products
22	B	82.0%	Knowledge	Environmental Chemistry	Evaluate plant growth data and infer the graphical relationship based on the data
23	B	52.0%	Skills	Environmental Chemistry	Determine two controlled variables in an investigation
24	A	75.8%	Knowledge	Environmental Chemistry	Identify an organic nutrient located in a concept map
25	A	59.2%	Skills	Environmental Chemistry	Identify the reason for changes in the level of a pollutant in a river
26	C	32.1%	Skills	Environmental Chemistry	Identify an organic substance that is produced in plants
27	D	76.2%	Skills	Environmental Chemistry	Evaluate food chain information to identify the process of biomagnification
28	A	72.2%	Knowledge	Environmental Chemistry	Identify acids, bases and neutral substances based on statements about their pH
29	C	74.1%	Knowledge	Environmental Chemistry	Determine the water conditions most suitable for species diversity

Question	Key	Correct Response	Reporting Category	Unit	Item Description
30	A	77.1%	Skills	Environmental Chemistry	Identify the mechanism for the movement of oil after an oceanic oil spill
NR3	100	59.3%	Knowledge	Environmental Chemistry	Determine a LD50 value for a given chemical based on information in a graph
31	B	58.3%	Skills	Electrical Principals and Technologies	Associate electron flow with the components of a hydro-flow model
32	A	79.5%	Knowledge	Electrical Principals and Technologies	Determine the component that is protected by a circuit breaker in a schematic diagram
33	A	57.3%	Skills	Electrical Principals and Technologies	Determine the most effective components of a wet cell
34	D	60.4%	Skills	Electrical Principals and Technologies	Analyze a circuit to determine what changes will occur when a bulb wired in parallel burns out
35	A	71.1%	Skills	Electrical Principals and Technologies	Identify a characteristic of static electricity
NR4	4132	54.4%	Skills	Electrical Principals and Technologies	Calculate the efficiency of a variety of devices and rank them from least efficient to most efficient
36	C	63.4%	Knowledge	Electrical Principals and Technologies	Evaluate a source to determine the percentage of fossil fuel use in Canada
37	C	58.2%	Knowledge	Electrical Principals and Technologies	Evaluate a design for a generator and determine which modification would have no effect on the current produced
38	B	81.9%	Skills	Electrical Principals and Technologies	Calculate the energy used by a flashlight for a given period of time
39	B	44.6%	Knowledge	Electrical Principals and Technologies	Indicate ways in which the resistance of a wire can be reduced
40	C	53.6%	Skills	Electrical Principals and Technologies	Identify the energy transformation that occurs in a thermocouple

Question	Key	Correct Response	Reporting Category	Unit	Item Description
41	B	73.7%	Skills	Space Exploration	Identify a risk associated with space junk
42	C	80.4%	Skills	Space Exploration	Identify a comet's size of orbit based on a chart
43	A	57.8%	Skills	Space Exploration	Identify the propulsion method used to launch the space shuttle into space
NR5	231	80.3%	Knowledge	Space Exploration	Classify statements as political, environmental or ethical
44	A	76.4%	Knowledge	Space Exploration	Identify a manipulated variable in an experiment based on a source
45	B	46.6%	Knowledge	Space Exploration	Analyze planetary data to infer the position of an unknown planet
46	D	59.8%	Skills	Space Exploration	Determine which star shown in a diagram has a given altitude and azimuth
47	D	47.5%	Skills	Space Exploration	Identify a diagram that represents a geocentric model of the universe
48	B	67.4%	Skills	Space Exploration	Identify a device that would be used to determine the composition of a celestial body
49	A	67.8%	Skills	Space Exploration	Compare and contrast optical and radio telescopes
50	A	47.3%	Skills	Space Exploration	Identify a celestial object based on a definition

2012 Achievement Test Questions

The questions presented in this document are from the previously secured 2012 Grade 9 Science Achievement Test and are representative of the questions that form achievement tests. These questions are released by Alberta Education for teacher and student use.

2012 Grade 9 Science Achievement Test

1. When the living conditions in a habitat change rapidly, the organisms that are **most likely** to become extirpated are
 - A. generalists that occupy a broad niche
 - B. generalists that occupy a narrow niche
 - C. specialists that occupy a broad niche
 - D. specialists that occupy a narrow niche

Use the following information to answer question 2.

Dairy farmers have bred dairy cattle over many generations in order to increase the volume of milk that each cow can produce.

2. This process is called
 - A. natural selection
 - B. discrete variation
 - C. artificial selection
 - D. continuous variation

Use the following information to answer question 3.

A female cat with white fur and a male cat with black fur produce three black kittens.

3. White fur colour is *i* in cats, and if the two cats described above had a fourth kitten, it would be *ii* .

The statement above is completed by the information in row

Row	<i>i</i>	<i>ii</i>
A.	dominant	black
B.	dominant	grey
C.	recessive	black
D.	recessive	grey

Use the following information to answer question 4.

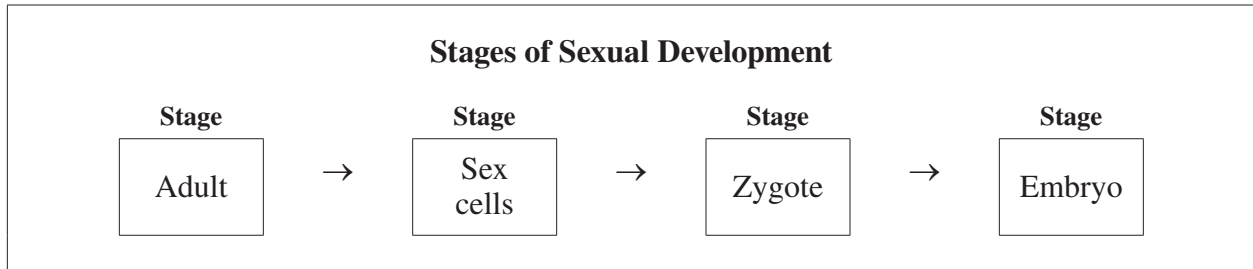

4. One of the stages in which cells contain the normal number of chromosomes is labelled *i* , and the stage in which cells contain only half the normal number of chromosomes is labelled *ii* .

The statement above is completed by the information in row

Row	<i>i</i>	<i>ii</i>
A.	adult	zygote
B.	zygote	sex cells
C.	sex cells	embryo
D.	embryo	adult

Use the following information to answer numerical-response question 1.

Genetically Important Components		
1	2	3
<ul style="list-style-type: none"> • a small segment located at a particular location • determines a specific characteristic of an organism 	<ul style="list-style-type: none"> • defects in this component can cause observable effects on organisms • most human cells contain 23 pairs 	<ul style="list-style-type: none"> • inherited material responsible for variation • can be used as a genetic fingerprint

Numerical Response

1. Match the column heading number from the chart above with its correct component listed below.

DNA

Genes

Chromosomes

(Record all **three digits** of your answer in the numerical-response section on the answer sheet.)

Use the following information to answer question 5.

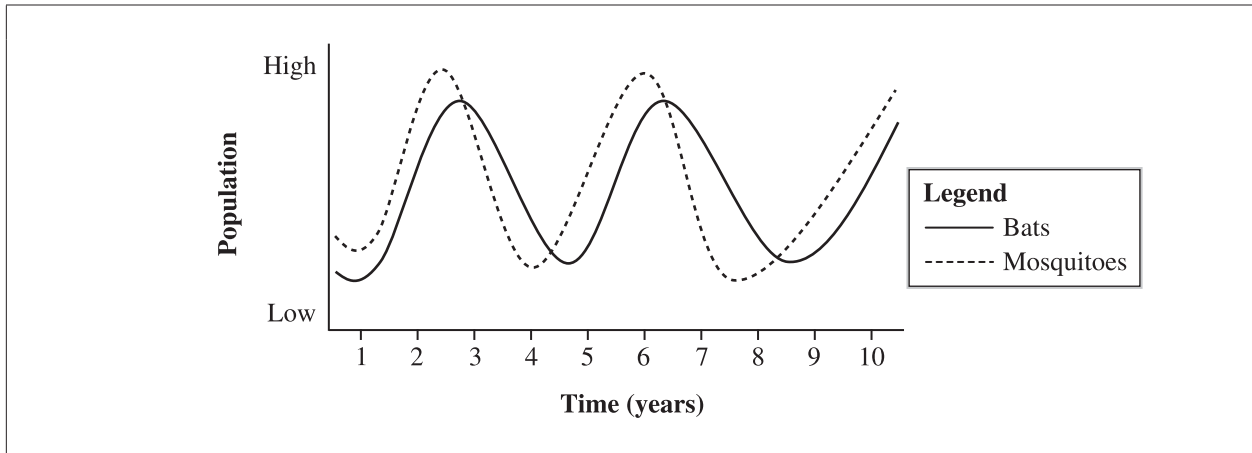

5. If the population of the predator species is reduced due to an illness, then the population of its prey species will likely
- A. decrease because competition will increase
 - B. increase because competition will decrease
 - C. decrease because predation will increase
 - D. increase because predation will decrease
-

Use the following information to answer question 6.

Shara takes cuttings from her red geranium plants every year and uses them to produce more geranium plants for the following year.

6. Which of the following statements **most likely** describes one advantage of Shara's gardening practice?
- A. The plants produced would be a variety of colours.
 - B. If conditions changed, most of the plants would survive.
 - C. It would take a short period of time to reproduce many plants.
 - D. There would be genetic variation among the individual plants.

7. *Land-based ecosystems tend to have more i species than ii species, and the number of different species tends to iii the farther the ecosystem is from the equator.*

The statement above is completed by the information in row

Row	<i>i</i>	<i>ii</i>	<i>iii</i>
A.	mammal	insect	increase
B.	mammal	insect	decrease
C.	insect	mammal	increase
D.	insect	mammal	decrease

Use the following information to answer question 8.

To control the rat population, British explorers introduced the Indian mongoose to the Fijian Islands. Not only do Indian mongooses prey on rats, but they also prey on Fiji's ground-dwelling birds. As a result, the status of these birds in some areas of Fiji has been affected, as described below.

- 1 In the lowland regions of Fiji, some species of ground-dwelling birds are no longer found.
- 2 In the rainforest regions of Fiji, the number of ground-dwelling birds is declining rapidly.
- 3 In the remote mountain forests, several species of ground-dwelling birds are not preyed upon by mongooses.

To measure the impact of the mongooses, scientists conducted a study of all ground-dwelling bird species in various regions over a five-year period.

8. The responding variable in this study is the
- A. duration of the study
 - B. size of the study sample
 - C. number of mongooses present
 - D. number of bird species present

Use the following information to answer question 9.

Segments of DNA are spliced together to produce rare proteins used in medicines.

9. The process described above is an example of which of the following biotechnologies?
- A. Genetic engineering
 - B. In vitro fertilization
 - C. Selective breeding
 - D. Genetic cloning
-

Use the following information to answer question 10.

Molly has blonde hair, short legs, and can roll her tongue. She can also play the piano very well.

10. Which of the following rows identifies examples of discrete variation and continuous variation?

Row	Discrete Variation	Continuous Variation
A.	Leg length	Ability to roll tongue
B.	Ability to roll tongue	Leg length
C.	Ability to play piano	Natural hair colour
D.	Natural hair colour	Ability to play piano

11. The melting of ice is considered a
- A. chemical change, because a new substance is formed
 - B. physical change, because a new substance is formed
 - C. chemical change, because the process is reversible
 - D. physical change, because the process is reversible

Use the following information to answer question 12.

Title: _____ ?

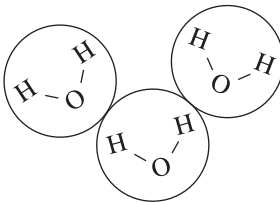

The diagram shows three water molecules. Each molecule is represented by a circle containing one oxygen atom (O) and two hydrogen atoms (H) bonded together. The three molecules are arranged in a triangular pattern, with one molecule at the top and two at the bottom.

12. Which of the following titles is appropriate for the diagram above?
- A. "One Atom of Water"
 - B. "Three Atoms of Water"
 - C. "One Molecule of Water"
 - D. "Three Molecules of Water"

Use the following information to answer question 13.

Chris listed four chemical formulas and their matching chemical names in his notebook, as shown below.

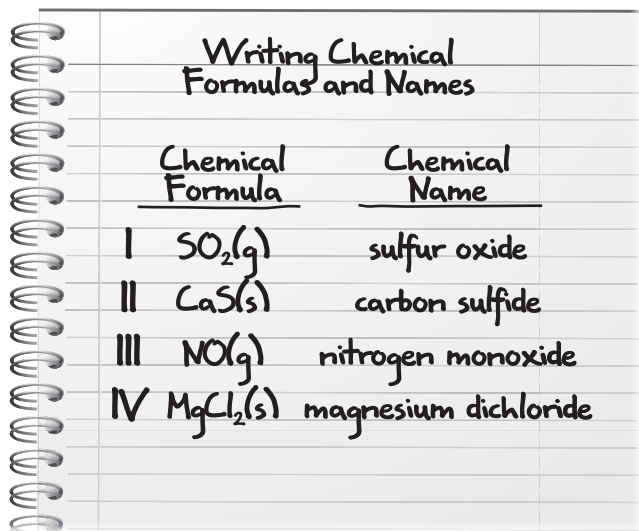

	<u>Chemical Formula</u>	<u>Chemical Name</u>
I	SO ₂ (g)	sulfur oxide
II	CaS(s)	carbon sulfide
III	NO(g)	nitrogen monoxide
IV	MgCl ₂ (s)	magnesium dichloride

According to Chris' teacher, he named only one of the compounds correctly.

13. Which of the compounds did Chris correctly name?

- A. I
- B. II
- C. III
- D. IV

Use the following information to answer question 14.



14. Which of the following statements accurately describes the reaction above?

- A. Combining hydrogen gas and chlorine gas produces hydrochloric acid.
- B. Combining hydrochloric acid with hydrogen gas produces chlorine gas.
- C. Hydrogen gas is produced when hydrochloric acid is combined with chlorine gas.
- D. Hydrogen gas and chlorine gas are produced when hydrochloric acid is broken down.

Use the following information to answer question 15.

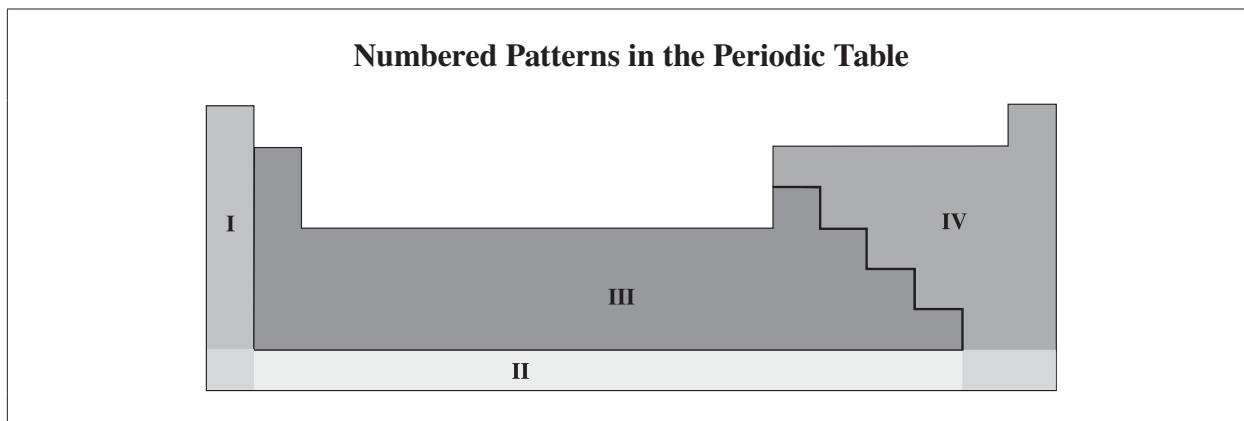

15. Identify the row that correctly describes the patterns in the periodic table above.

Row	I	II	III	IV
A.	A family	A period	Non-metals	Metals
B.	A family	A period	Metals	Non-metals
C.	A period	A family	Metals	Non-metals
D.	A period	A family	Non-metals	Metals

Use the following information to answer question 16.

A student dissolves sugar in a beaker of water.

16. Individually, the water and the sugar are classified as *i* and the combination of both substances is a *ii* .

The statement above is completed by the information in row

Row	<i>i</i>	<i>ii</i>
A.	compounds	solution
B.	compounds	mechanical mixture
C.	elements	solution
D.	elements	mechanical mixture

Use the following information to answer question 17.

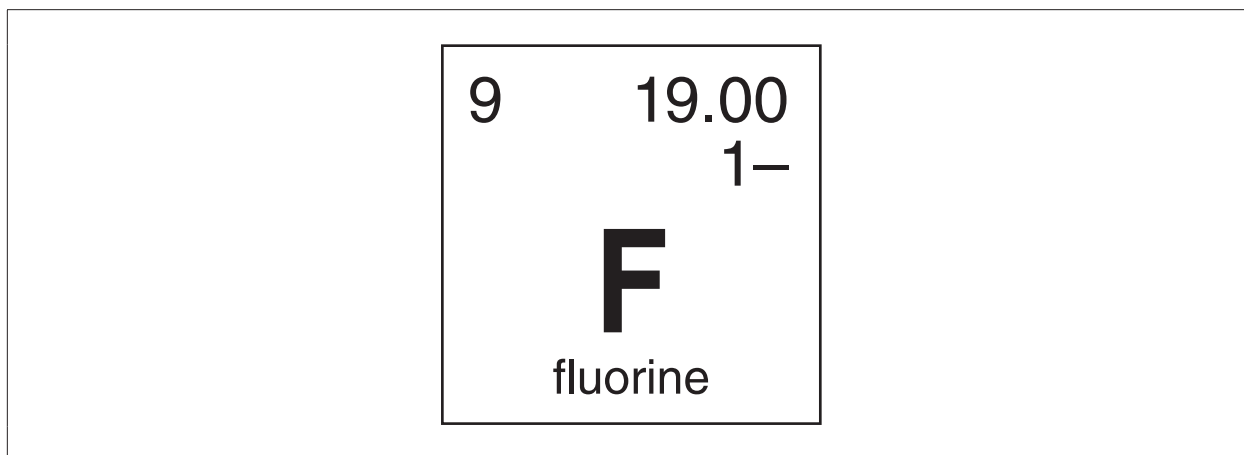

17. The information above shows that a fluorine atom has *i* electrons and *ii* neutrons.

The statement above is completed by the information in row

Row	<i>i</i>	<i>ii</i>
A.	9	10
B.	9	28
C.	19	28
D.	19	10

18. Combustion and corrosion are similar reactions because they both
- A. have a metal as a reactant
 - B. release oxygen as a product
 - C. require oxygen as a reactant
 - D. release carbon dioxide as a product

Use the following information to answer question 19.

When magnesium metal is placed in hydrochloric acid, hydrogen gas bubbles are produced.

19. Which of the following combinations of reactants would have the **fastest** reaction rate?

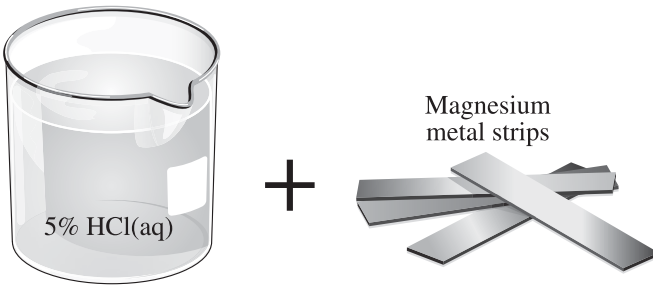
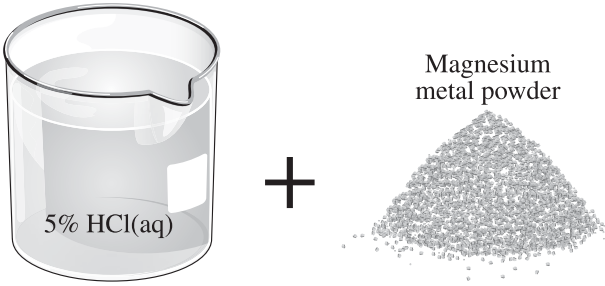
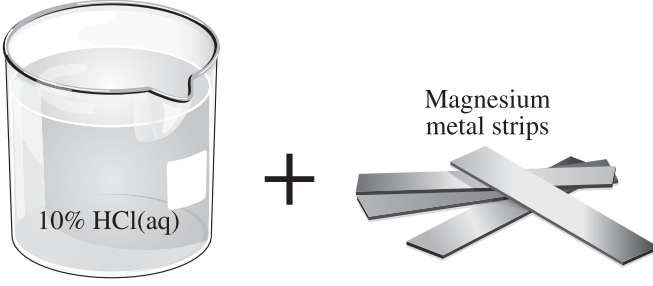
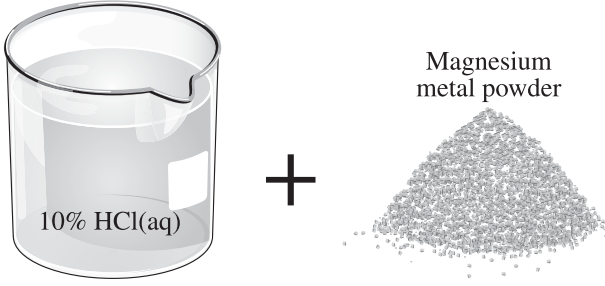
Row	
A.	 <p>5% HCl(aq) + Magnesium metal strips</p>
B.	 <p>5% HCl(aq) + Magnesium metal powder</p>
C.	 <p>10% HCl(aq) + Magnesium metal strips</p>
D.	 <p>10% HCl(aq) + Magnesium metal powder</p>

Use the following information to answer question 20.

In a science demonstration, a teacher combined fluorescent dye, hydrogen peroxide, and a chemical called CPPO. The resulting solution produced heat and a bright green glow.

20. Which type of reaction did the teacher demonstrate?

- A. Endothermic
 - B. Combustion
 - C. Exothermic
 - D. Corrosion
-

Use the following information to answer numerical-response question 2.

Substance	Conducts Electricity	State at Room Temperature
X	No	Gas
Y	Yes	Solid
Z	No	Liquid

Numerical Response

2. Classify the substances above as ionic or molecular using the following code.

1 = Ionic

2 = Molecular

X

Y

Z

(Record your answer in the numerical-response section on the answer sheet.)

Use the following information to answer question 21.

Substances that biodegrade are often considered “green” products because they have a low impact on the environment. Information about five waste products is listed below.

Substance	Recyclable	Toxic waste
Plastic ring holders for cans	✓	?
Aluminum cans	✓	✗
Plastic shopping bags	✓	?
Orange peels		✗
Paper	✓	✗

Time it Takes for Products to Biodegrade

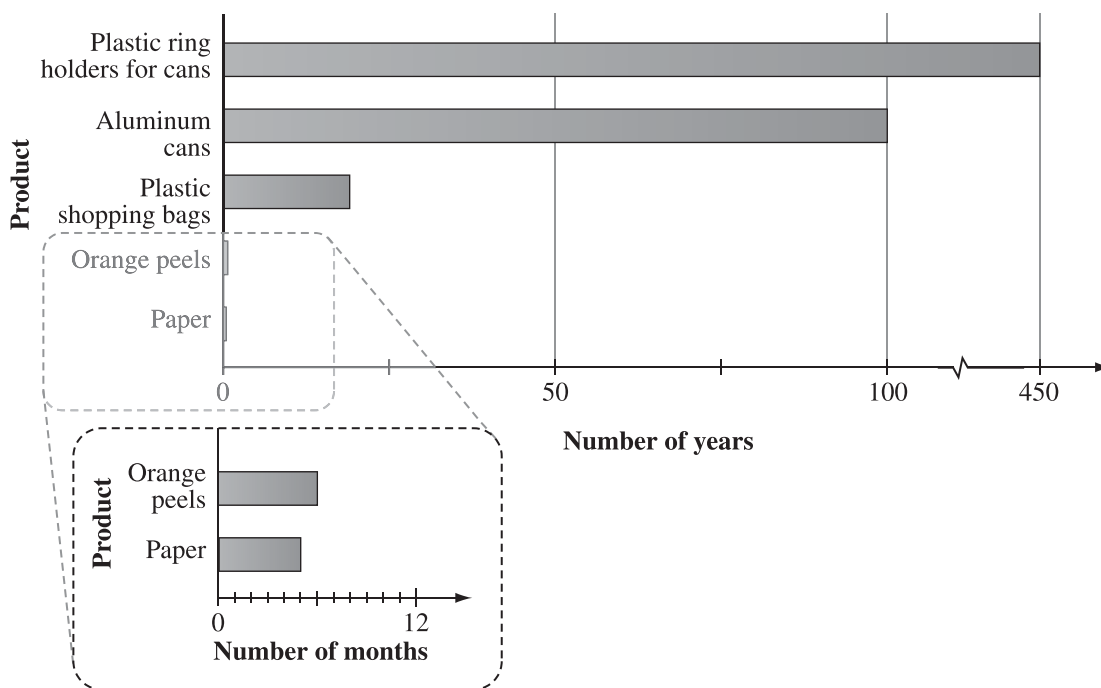

21. Aluminum cans and the plastic ring holders should **not** be considered “green” products because they
- A. may produce toxic waste
 - B. take too long to biodegrade
 - C. can be recycled and re-used
 - D. take up too much space in landfills

Use the following information to answer question 22.

In an experiment, students planted three groups of seeds from the same species of plant. All three groups of planted seeds were grown under identical conditions except for the concentration of fertilizer applied. The average height of the plants in each group was recorded after five days.

Results of the Experiment After Five Days

Concentration of Fertilizer	Average Height of Plants (cm)
Low (0.5 g/L)	3
Medium (1 g/L)	5
High (5 g/L)	1

22. According to the data above, which of the following graphs models the relationship between plant growth and fertilizer use?

A.

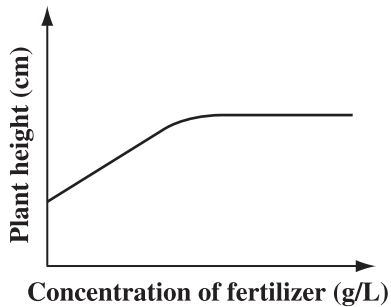

B.

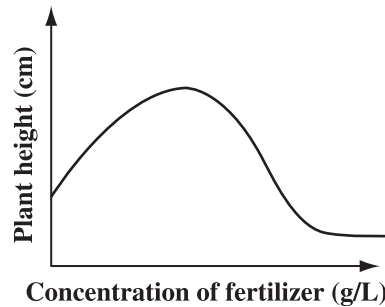

C.

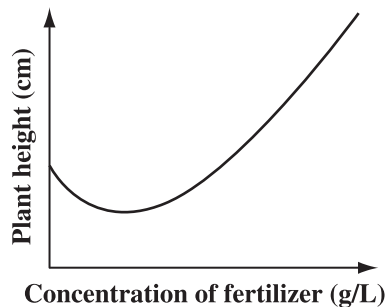

D.

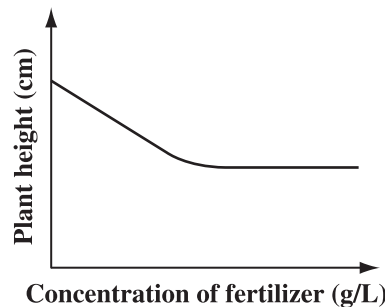

Use the following information to answer question 23.

The graph below shows the death rate of mosquitoes that are exposed to different concentrations of pesticide X.

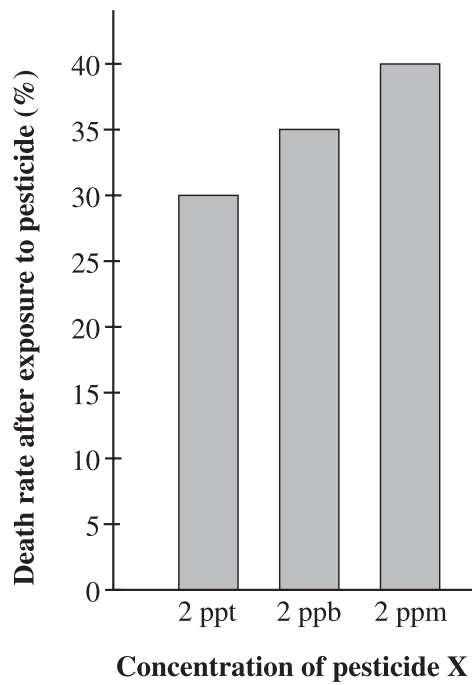

Variables of the Investigation

- 1 Type of pesticide
- 2 Pesticide concentration
- 3 Death rate of mosquitoes
- 4 Method of pesticide application

23. In the investigation that generated the data for the graph above, two controlled variables are numbered
- A. 1 and 3
 - B. 1 and 4
 - C. 2 and 3
 - D. 2 and 4

Use the following information to answer question 24.

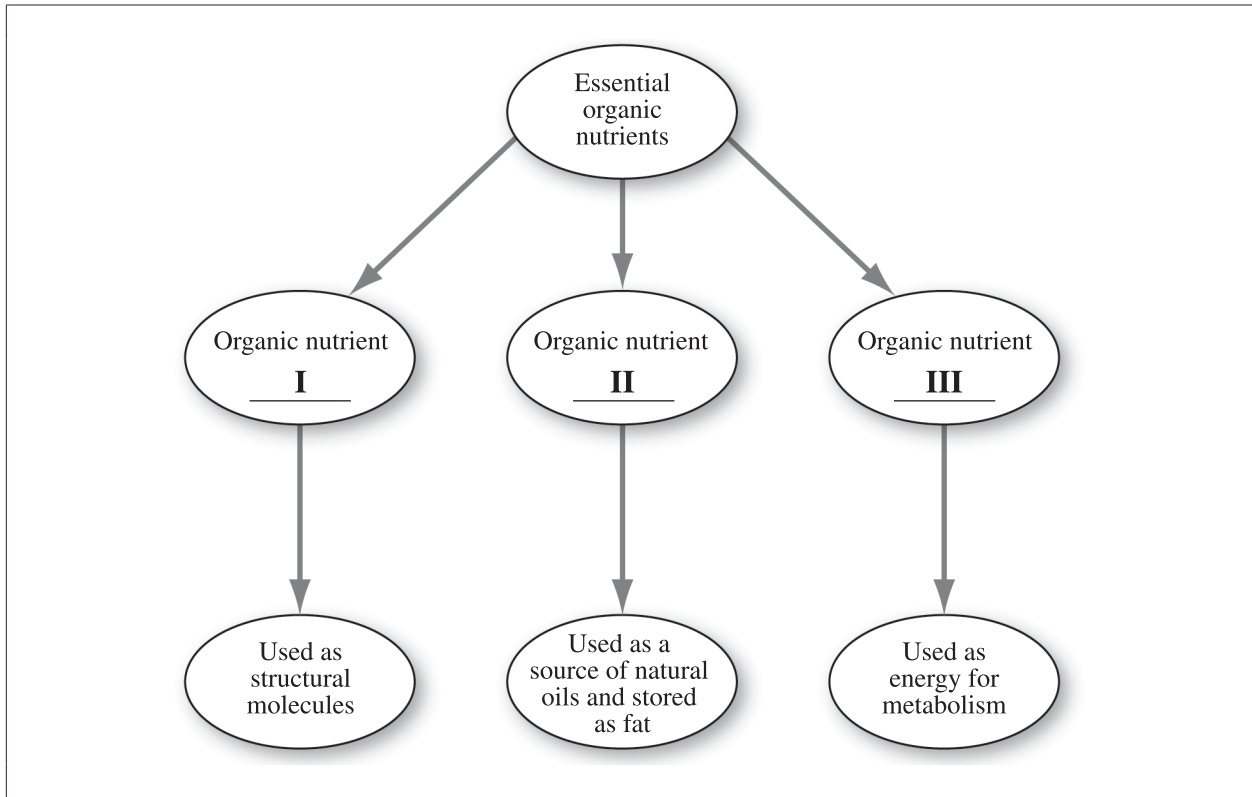

24. The nutrient that fits into space II is classified as a

- A. lipid
 - B. protein
 - C. trace element
 - D. macronutrient
-

Use the following information to answer question 25.

A researcher determines that the mercury levels in a river decrease as the water flows downstream from a factory.

25. The decrease in the mercury levels is **most likely** the result of

- A. dilution
- B. neutralization
- C. biodegradation
- D. bioaccumulation

26. Which of the following substances is organic and can be produced by plants?
- A. $\text{H}_2\text{O}(\text{l})$ (water)
 - B. $\text{O}_2(\text{g})$ (oxygen)
 - C. $\text{C}_{12}\text{H}_{22}\text{O}_{11}(\text{s})$ (sucrose)
 - D. $\text{CO}_2(\text{g})$ (carbon dioxide)

Use the following information to answer question 27.

DDT Concentrations in a Marine Food Chain

Plankton (15 ppb) → Squid (22 ppb) → Tuna (43 ppb) → Shark (5 200 ppb)

27. The information above **best** illustrates
- A. diffusion
 - B. dispersion
 - C. biodegradation
 - D. biomagnification

Use the following information to answer question 28.

Four Students' Statements About the pH Scale

- Student I** Acids have a lower pH than bases.
Student II Bases are located at the beginning of the pH scale, starting at 1.
Student III An exactly neutral substance has a pH of 7.
Student IV Weak bases have the highest pH value.

28. Which two students provided statements that are correct?

- A. Students I and III
 - B. Students I and IV
 - C. Students II and III
 - D. Students III and IV
-

Use the following information to answer question 29.

Water Sample	Dissolved Oxygen (ppm)	pH	Phosphorus Concentration
1	3.4	5.6	High
2	6.0	7.0	Low
3	2.0	4.5	High
4	5.5	6.0	High

29. Which water samples would support the greatest diversity of organisms?

- A. Samples 1 and 2
- B. Samples 1 and 3
- C. Samples 2 and 4
- D. Samples 3 and 4

Use the following information to answer question 30.

Distribution of Oil from the Exxon Valdez Oil Spill

After the Exxon Valdez oil spill on March 24, 1989, the oil was tracked as it moved from the site of the spill to the surrounding environment.

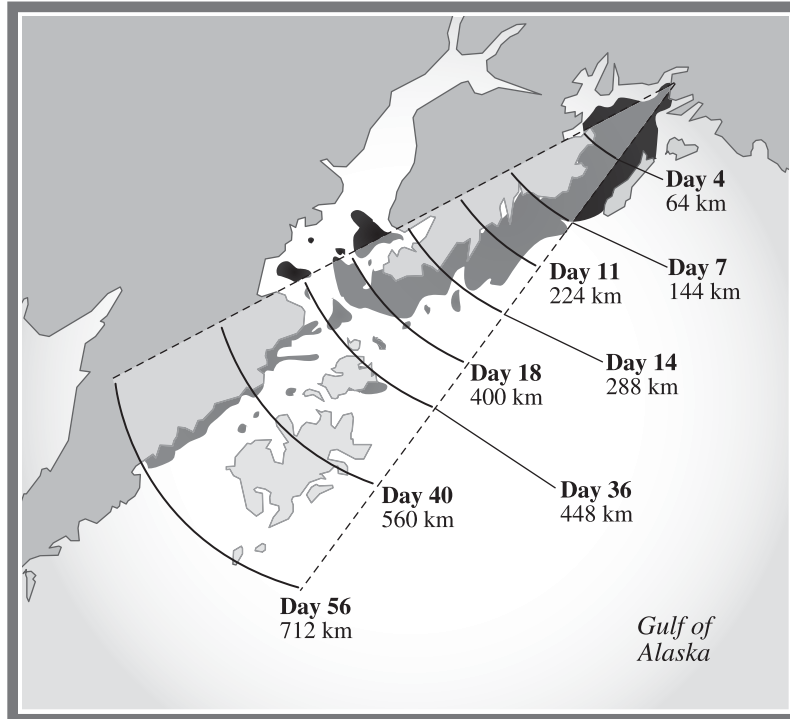

30. The movement of the oil through the water to different locations around the spill represents the process of
- A. dispersion
 - B. dissolving
 - C. deposition
 - D. degradation

Use the following information to answer numerical-response question 3.

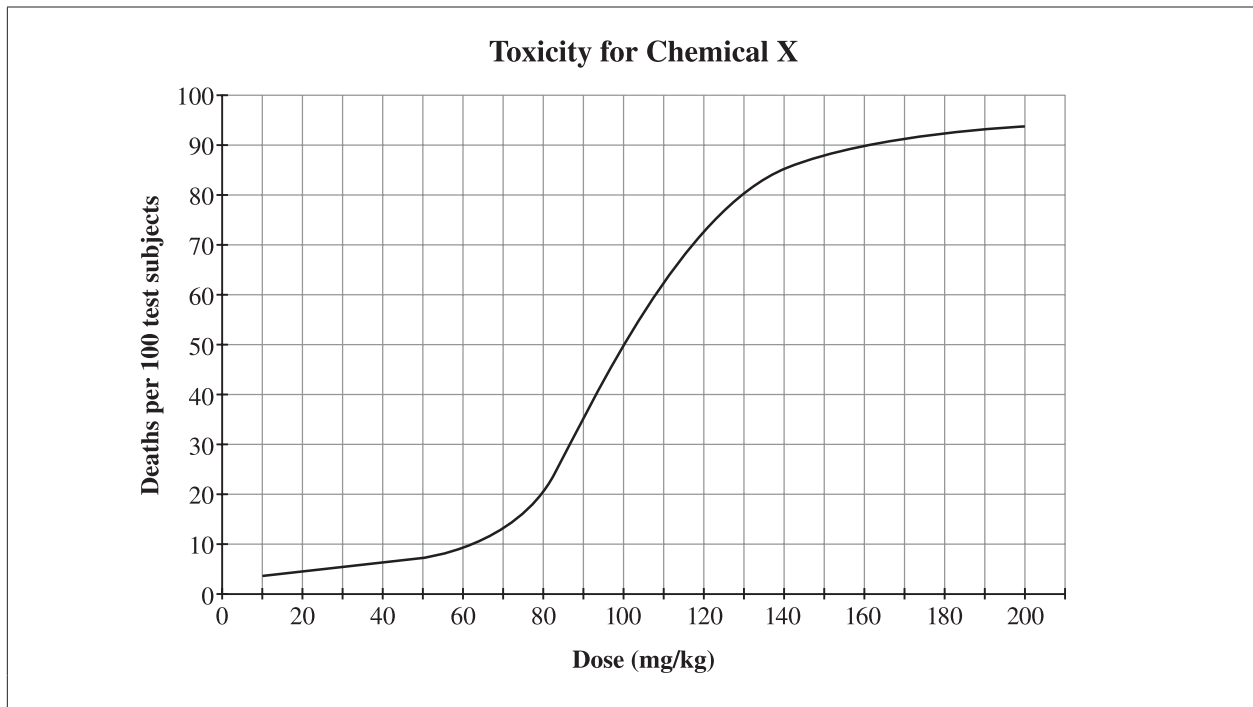

Numerical Response

3. To the nearest milligram per kilogram, the LD₅₀ value for Chemical X is _____ .

(Record your answer in the numerical-response section on the answer sheet.)

Use the following information to answer question 31.

A student is asked to explain the relationship between current, voltage, and resistance using a hydro-flow model, as shown below.

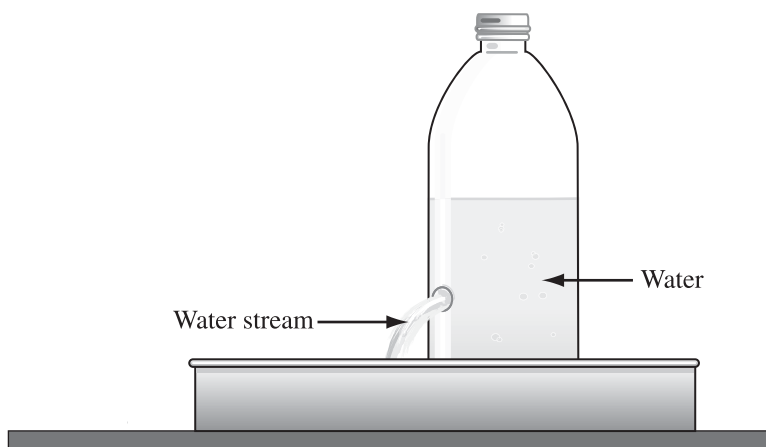

31. The water in the model could be used to represent
- A. protons
 - B. electrons
 - C. electrodes
 - D. electrolytes

Use the following information to answer question 32.

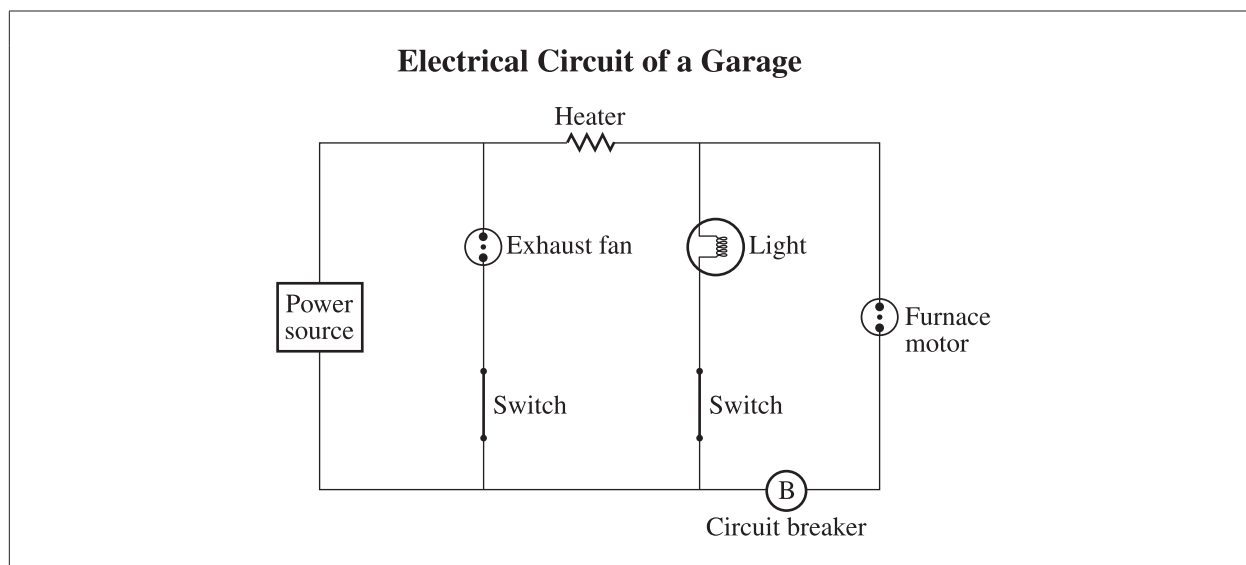

32. The component that is protected by the circuit breaker when both switches are closed is the
- A. furnace motor
 - B. exhaust fan
 - C. heater
 - D. light

33. Which of the following electrode and electrolyte combinations could transfer electrons when connected in a circuit?

Row	Electrode 1	Electrode 2	Electrolyte Solution
A.	Zinc	Copper	Salt water
B.	Copper	Copper	Salt water
C.	Zinc	Copper	Distilled water
D.	Copper	Copper	Distilled water

Use the following diagram to answer question 34.

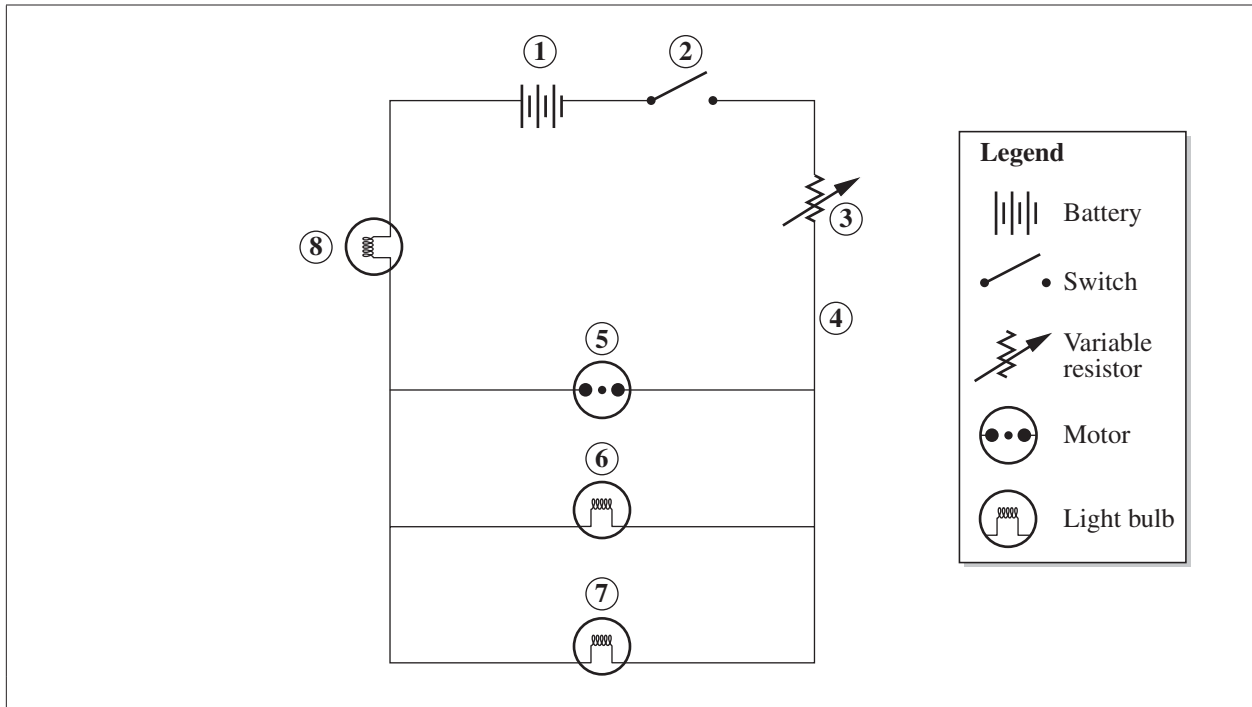

34. If the light bulb at position 6 burns out while the switch at position 2 is closed, then the

- A. light bulb at position 7 will dim and the motor will spin more slowly
- B. remaining two light bulbs will turn off and the motor will cease to spin
- C. light bulb at position 7 will brighten and the motor will spin more quickly
- D. remaining two light bulbs will remain lit and the motor will continue to spin

35. The reason that static electricity **cannot** run an electrical device is because static electricity

- A. cannot supply a continuous flow of electrons
- B. cannot flow through the device's conductors
- C. does not provide enough voltage
- D. does not provide enough current

Use the following information to answer numerical-response question 4.

Device	Input Energy (kJ)	Output Energy (kJ)
1	675.0	79
2	9.0	9.0
3	13.0	3.0
4	0.781	0.031

Numerical Response

4. List the devices shown above from the **least** efficient to the **most** efficient.

_____, _____, _____, and _____
Least efficient **Most efficient**

(Record all **four digits** of your answer in the numerical-response section on the answer sheet.)

Use the following information to answer question 36.

Total Energy Consumption in Canada, Classified by Source (2006)

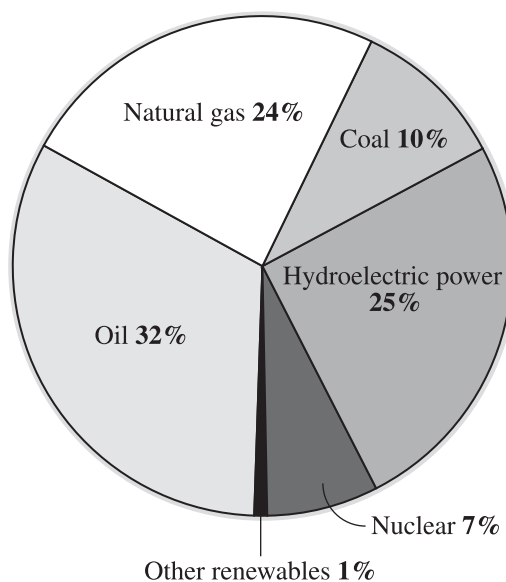

36. How much of the energy consumed in Canada in 2006 was provided by fossil fuels?

- A. 34%
- B. 56%
- C. 66%
- D. 73%

Use the following information to answer question 37.

When the south pole of the magnet is moved into the coil of wire, current flows and there is a reading on the galvanometer.

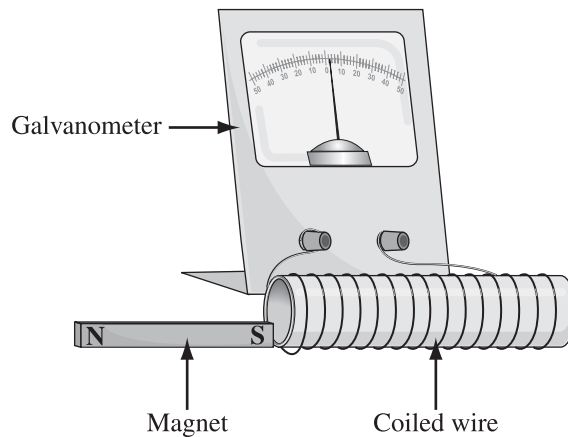

37. Which of the following changes would **not** increase the reading on the galvanometer?
- A. Moving the magnet faster in the coil
 - B. Wrapping more wire around the coil
 - C. Reversing the poles of the magnet
 - D. Using a stronger magnet

Use the data sheet to answer question 38.

The power rating of Alex's flashlight is 4.5 W and he uses it for a time of 60 s. Knowing these values, Alex can use the energy formula to calculate the amount of energy used by his flashlight.

38. The total energy used by the flashlight in 60 s is
- A. 4.5 J
 - B. 270 J
 - C. 450 J
 - D. 2 700 J

39. The resistance of a wire can be reduced by *i* the diameter of the wire or by *ii* the length of the wire.

The statement above is completed by the information in row

Row	<i>i</i>	<i>ii</i>
A.	decreasing	decreasing
B.	increasing	decreasing
C.	decreasing	increasing
D.	increasing	increasing

40. In order for a thermocouple to function properly, which energy transformation must occur?

- A. Electrical energy to mechanical energy
- B. Mechanical energy to electrical energy
- C. Thermal energy to electrical energy
- D. Electrical energy to thermal energy

41. Space junk can potentially damage spacecraft or the space station because space junk

- A. reflects cosmic rays
- B. travels at high speeds
- C. produces a lot of heat
- D. produces attractive forces

Use the following information to answer question 42.

In 2006, scientists predicted the years when comets would approach Earth based on the approximate lengths of their orbits, which were calculated in years.

Name of Comet	Year of Close Approach to Earth	Year of Next Expected Close Approach to Earth
Kowal 1	2007	2022
Arend	2007	2015
Spitaler	2008	2015
Mueller 4	2010	2019

42. According to the information shown above, which comet has the **smallest** orbit around the Sun?

- A. Kowal 1
 - B. Arend
 - C. Spitaler
 - D. Mueller 4
-

43. Space shuttles are propelled into space by

- A. chemical propulsion
- B. nuclear propulsion
- C. solar propulsion
- D. ion propulsion

Use the following information to answer numerical-response question 5.

- Statement 1** Humans should send animals into space to test the effects of zero gravity.
Statement 2 There are no regulations regarding military uses of space.
Statement 3 Dead satellites and other space junk litter Earth's orbit.

Numerical Response

5. Match each of the statements listed above with the type of issue to which it refers below.

Political _____ (Record in the **first** column)

Environmental _____ (Record in the **second** column)

Ethical _____ (Record in the **third** column)

(Record all **three digits** of your answer in the numerical-response section on the answer sheet.)

Use the following information to answer question 44.

Four students conduct an experiment to determine which scenario will provide the best estimate of the distance to a flagpole.

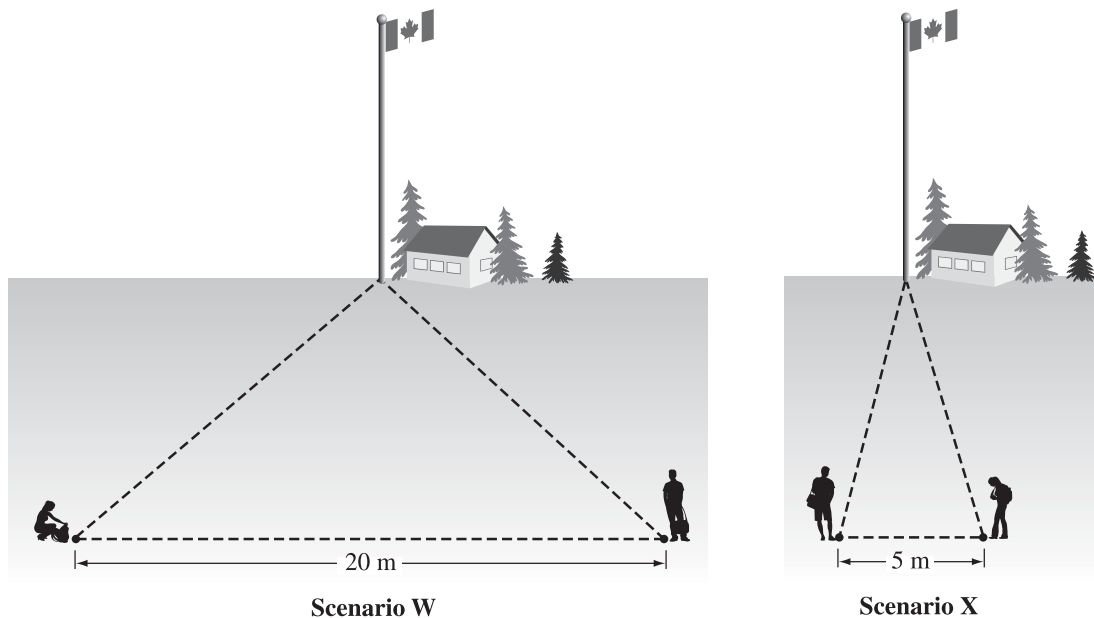

44. The manipulated variable in the experiment above is the
- A. baseline length
 - B. height of the flagpole
 - C. distance to the bottom of the flagpole
 - D. angle of elevation to the top of the flagpole

Use the following information to answer question 45.

An unknown gaseous planet has a radius of 24 764 km, a period of rotation of 0.67 Earth days, and a period of revolution of 60 190 Earth days.

Planet	Radius (km)	Period of Rotation (Earth days)	Period of Revolution (Earth days)	Planet Composition
Earth	6 378	1.00	365	Terrestrial
Mars	3 397	1.03	687	Terrestrial
Saturn	60 268	0.44	10 756	Gaseous
Uranus	25 559	0.72	30 687	Gaseous

45. The unknown planet would be found
- inside Earth's orbit
 - outside Uranus's orbit
 - between the orbits of Earth and Mars
 - between the orbits of Saturn and Uranus

Use the following information to answer question 46.

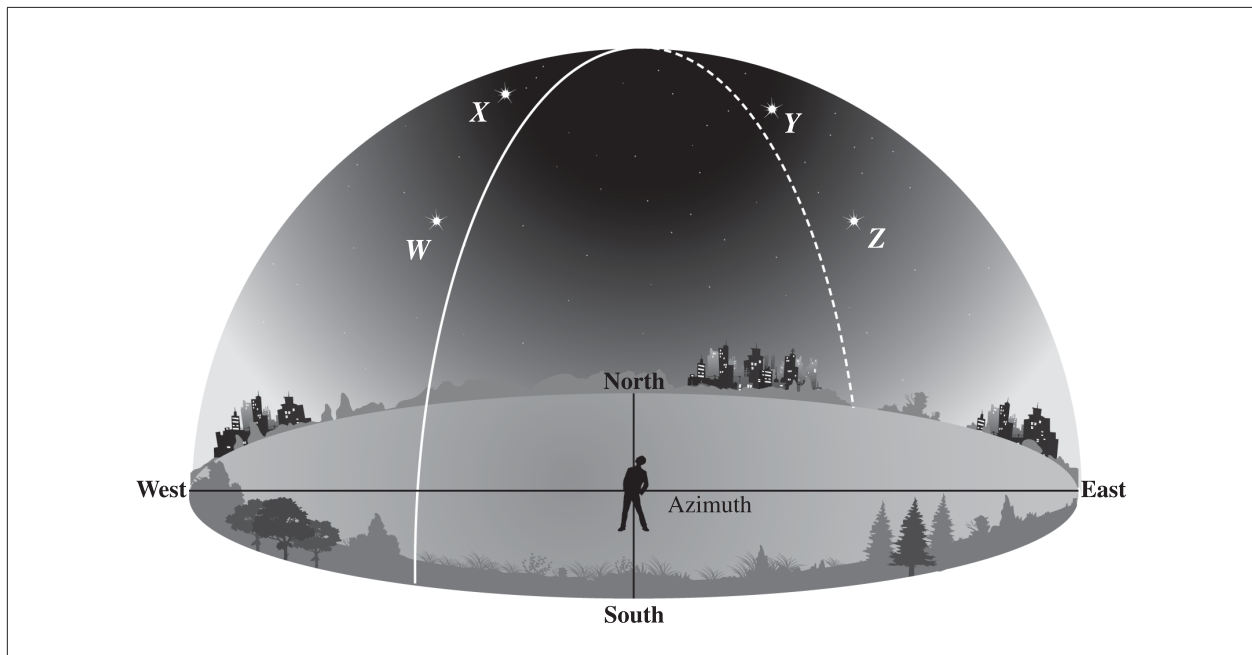

46. Which star is located at an altitude of approximately 40° and an azimuth of 40° ?
- Star W
 - Star X
 - Star Y
 - Star Z

Use the following information to answer question 47.

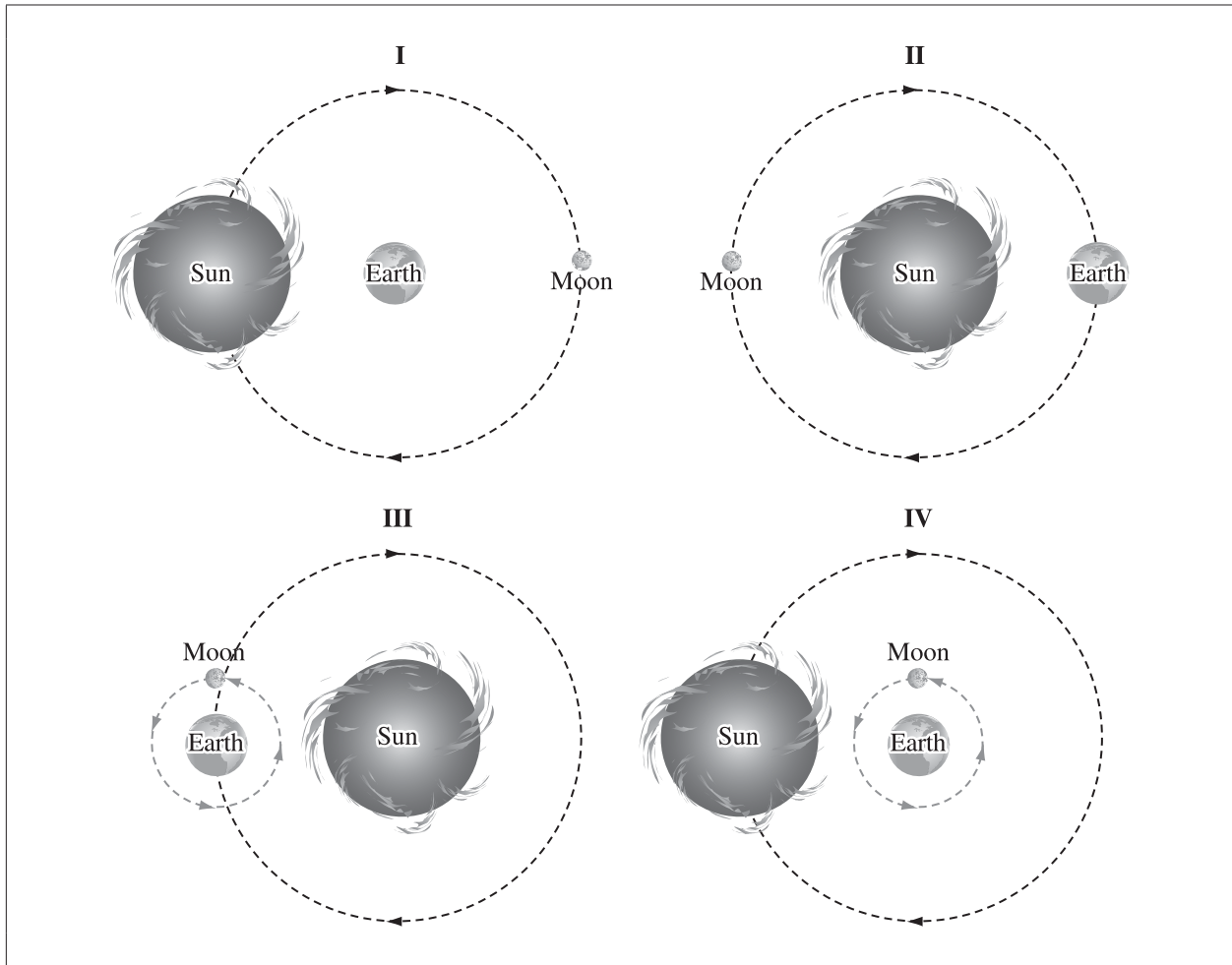

47. Which of the diagrams above represents Aristotle's geocentric model?

- A. I
- B. II
- C. III
- D. IV

48. Which of the following devices could be used to prove the presence of helium in the Sun's atmosphere?

- A. Radio telescope
- B. Spectroscope
- C. Space probe
- D. Satellite

49. An advantage of optical telescopes over radio telescopes is that optical telescopes can be used
- A. to produce clearer images of celestial objects
 - B. to observe a greater portion of the sky
 - C. when there is cloud cover
 - D. during the day or night
50. A vast collection of stars held together by gravitational attraction is called a
- A. galaxy
 - B. nebula
 - C. solar system
 - D. constellation

*You have now completed the test.
If you have time, you may wish to check your answers.*